

Ball valve HKSF

Ball valve HKSF

Design Features:

This fully welded and trunnion mounted (DN 80 and greater) ball valve and its sealing developed by RMA offer an economical, simple, robust and effective alternative for the ball valves of type „HKSF-W“. This ball valve is designed for operating pressures up to 50 bar (ANSI 300) and is completely maintenance-free.

The sealing of the spindle (O-rings) is exchangeable, the „anti-blow-out“-function is guaranteed. The ball sealing developed by RMA has a metal core, which ensures the required rigidity thus preventing „tilting“ or „braking off“.

The initial tightness is achieved by pre-tensioning of the sealing, when the pressure increases, the piston effect comes into effect and provides for additional application force of the soft sealing onto the ball.

By this sealing system the „double block and bleed“-function is also ensured.

Our manufacturing program comprises the following designs:

Nominal sizes: DN 15 up to DN 400
 DN 1/2“ up to DN 16“

Pressure ratings: PN 4, 10, 16, 25, 40
 ANSI Class 150, 300

Connections: flanges (DIN, ANSI)
 welding ends
 threads

Double Block and Bleed:

On request, the ball valve can be equipped with a special self-protected vent screw or with vent and drain pipes with an additional ball valve. Proof of sealing is provided by these accessories in both end positions even under full operating pressure.

Scope of Application:

Because of its construction this ball valve is designed for the media gas and oil. It is used i.e. in measuring and regulating stations, pig traps, compressor stations and regional gas distribution lines. Other applications on demand.

Temperature Range:

The temperature range for RMA-ball valves type „HKSF“ and „HKSF-E“ presently extends from -10° C to +80° C, special designs for high/low temperatures on request.

Ball valve HKSF

- with welding ends
- soft sealed
- full bore
- PN 4 - 50
- ANSI 150 - 300

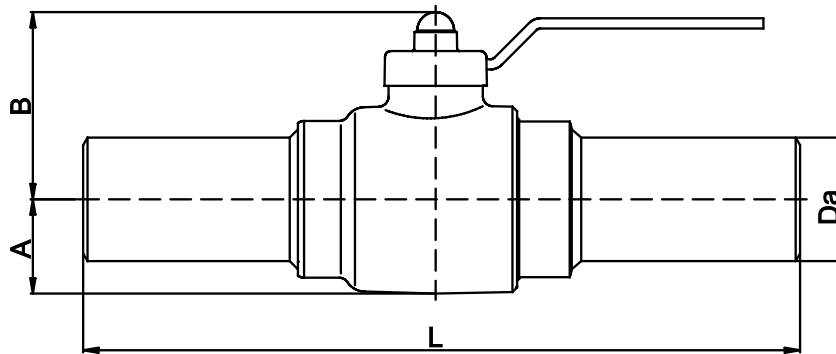

Size		Dimensions					Weight
DN		Da	A	B	L (PN 4 - 40)	L (ANSI 150-300)	G
[mm]	[inch]	[mm]	[mm]	[mm]	[mm]	[mm]	[kg]
25	1"	33,7	28	44	500	216	3,5
32	1¼"	42,4	43	57	500	216	5
40	1½"	48,3	43	57	500	216	5
50	2"	60,3	48	63	500	216	7,5
65	2½"	76,1	48	63	500	241	8
80	3"	88,9	94	106	390	283	17
100	4"	114,3	110	123	450	305	23
150	6"	148,3	163	173	600	457	55
200	8"	219,1	200	212	600	521	140
250	10"	273	225	295	787	559	190
300	12"	323,9	260	360	838	635	430
350	14"	355,6	295	385	889	762	620
400	16"	406,4	330	420	991	838	720

Remarks:

- As a standard with PUR-coating according to DIN 30677 T2.
- Other cover depths on request
- As far as required gear
- Drain / vent / block and bleed as well as emergency sealing asre possible on request

Ball valve HKSF

- soft sealed
- full bore
- PN 4 - 50
- ANSI 150 - 300

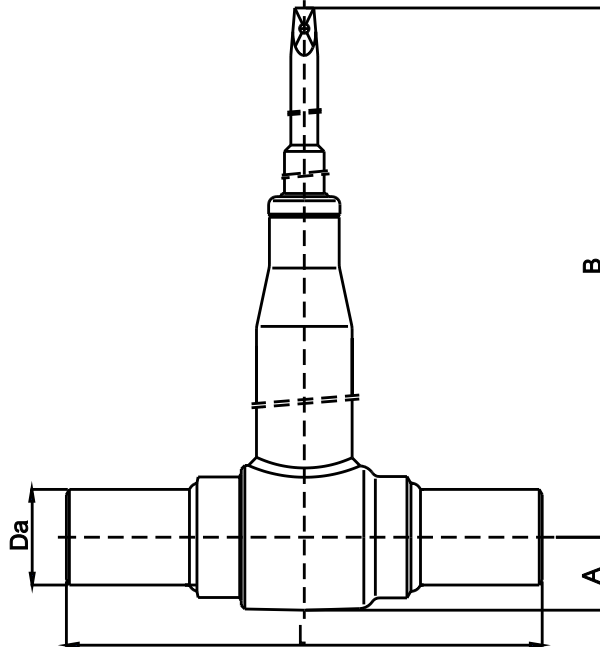

Size		Dimensions				Weight
DN	Da	A	B (min./max)	L (DIN/ANSI)	G	
[mm] [inch]	[mm]	[mm]	[mm]	[mm]	[kg]	
25	1"	33,7	28	676 / 1.026	500	5
32	1¼"	42,4	43	689 / 1.039	500	7
40	1½"	48,3	43	689 / 1.039	500	7
50	2"	60,3	48	695 / 1.045	500	10
65	2½"	76,1	48	695 / 1.045	500	11
80	3"	88,9	94	710 / 1.060	390	19
100	4"	114,3	110	730 / 1.080	450	25
150	6"	148,3	163	777 / 1.127	600	58
200	8"	219,1	200	820 / 1.170	600	145
250	10"	273	225	*	787 / 559	220
300	12"	323,9	260	*	838 / 635	460
350	14"	355,6	295	*	889 / 762	660
400	16"	406,4	330	*	991 / 838	760

* : Wird nach Kundenwunsch ausgeführt

Remarks:

- As a standard with PUR-coating according to DIN 30677 T2.
- Other cover depths on request
- As far as required gear
- Drain / vent / block and bleed as well as emergency sealing asre possible on request

Ball valve HKSF

- with flanges
- soft sealed
- full bore
- PN 4 - 40
- ANSI 150 - 300

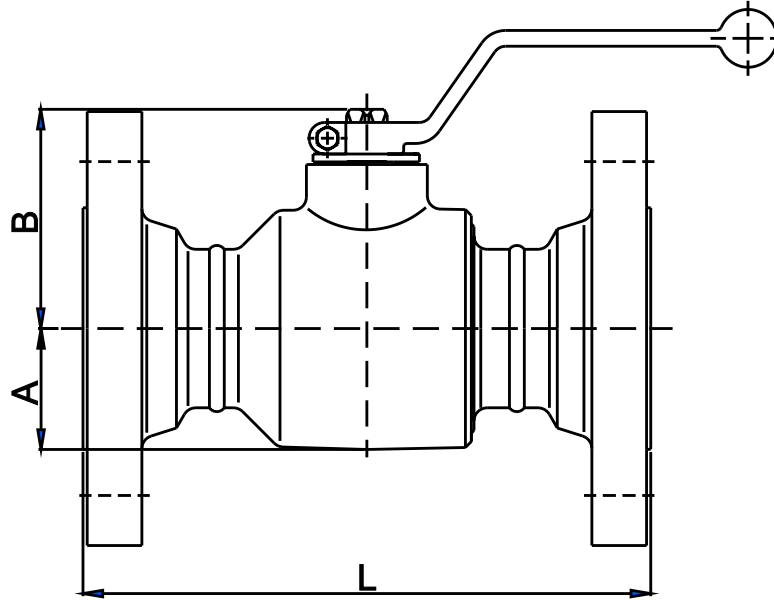

Size		Dimensions								Weights
DN		A	B	L (PN 10)	L (PN 16)	L (PN 25)	L (PN 40)	L (ANSI 150)	L (ANSI 300)	G
[mm]	[inch]	[mm]	[mm]	[mm]	[mm]	[mm]	[mm]	[mm]	[mm]	[kg]
25	1"	28	44	160	160	160	160	160	160	4
32	1¼"	43	57	180	180	180	180	180	180	6
40	1½"	43	57	200	200	200	200	200	200	6
50	2"	48	63	230	230	230	230	178	216	8
65	2½"	48	63	290	290	290	290	191	241	10
80	3"	94	106	180	180	180	180	203	283	19
100	4"	110	123	190	190	190	190	229	305	21
150	6"	163	173	350	350	350	350	394	403	55
200	8"	200	212	400	400	400	400	457	502	145
250	10"	225	295	533	533	650	650	533	568	240
300	12"	260	360	610	610	750	750	610	648	490
350	14"	295	385	686	686	850	850	686	762	710
400	16"	330	420	762	762	950	950	762	838	850

Remarks:

- As a standard the surfaces are yellow primed (RAL 1012).
- As far as required with gear
- Drain / vent / block and bleed as well as emergency sealing are possible on request.