

Operating, Installation and Maintenance Instructions



TABLE OF CONTENTS

1. Applicable documents	3
2. Information on intended use	3
3. Design / function	5
3.1 Ball valve	5
3.2 Sealant / lubrication system	5
4. Storage instructions	6
5. Unpacking and inspection	6
6. Indications on safe installation	7
6.1 Preparations	7
6.2 Handling	7
6.3 Installation	8
6.4 Water pressure test	9
6.5 Line drying	9
6.6 Leak test	10
7. Maintenance	11
8. Repair	11
8.1 Preparations	11
8.2 Repairing the external coating	11
9. Ball valve with individual parts	12

1. Applicable documents

The gear manufacturer's operating instructions also need to be followed for ball valves with gears.

2. Information on intended use

The valve is an extremely sturdy, fully welded ball valve for use in piping systems as a fluid shut-off valve.

It consists of a body with pipe connections, a spherical stopper, seals and an operating spindle.



The HKSF-W100 ball valve serves exclusively as a shut-off device.
The ball valve **must not** be used to reduce the flow of fluid.



The valve should only be moved to the limit of travel (end stop) in the FULLY OPEN or FULLY CLOSED position.

The identification label and the associated data sheets indicate the permitted operating data (in particular operating temperature and pressure). Exceeding these values damages the valve and may cause it to rupture.

The valve is a closed system. The way the seals are designed ensures permanent technical tightness under the specified operating conditions.

The fluid in the valve body can be released via drain or vent ports. These ports represent a hazard due to the blow-off pressure and the release of flammable substances that can form explosive atmospheres in contact with air.

Depending on its equipment category, the valve may be used in explosion protection zones 1, 2 and 3.

RMA Ball Valve Type "HKSF-W100"

Operating, Installation and Maintenance Instructions

The permissible ambient and fluid temperatures are factored into the design based on the operator's data.



Letter "X":

Since the temperature of the fluid determines the valve's operating temperature, the operator must specify the temperature class or highest surface temperature, complying with the temperature safety margins from EN13463-1.

Operating temperature °C ¹⁾	Temperature class
Up to 80	T6
Up to 95	T5
Up to 130	T4
¹⁾ A safety margin of 5°C (EN 13463-1 Section 13.3.3) was used in the table.	

3. Design / function

3.1 Ball valve

The body of the HKSF-W100 ball valve has been welded to ensure a complete seal. The ball is supported by a journal at the top and bottom (trunnion mounted).

The HKSF-W100 ball valve is supplied with one of the following sealing systems:

1. Primary metallic, secondary soft-sealing
2. Metallic sealing only

The standard sealing system is primary metallic, secondary soft-sealing.

With both systems, floating seating rings are arranged on both sides of the ball valve passage. These can adapt to the ball as necessary. The contact force is increased according to the pressure.

Primary metallic, secondary soft-sealing:

Soft seals that adapt to the ball as a function of the pressure, independently of the seating rings, are incorporated in the latter. The ball is chromium-plated and the seating rings are made of stainless steel.

Metallic sealing only:

Each seating ring has a metallic sealing surface but no soft seal. This sealing surface and the ball are coated with tungsten carbide.

The valve is supplied with a full bore with a smooth, round passage (piggable) or with a reduced passage.

The ball valve can be equipped with flanges, weld ends or other specified connections.

3.2 Sealant / lubrication system

According to customers' requirements, RMA ball valves can be equipped with integrated sealant systems on the seating rings and / or the spindle sleeve. Access is by means of a nipple (e.g. Alemite-Screw AEX 7/8"), either directly at the ball valve or through vertically extended pipes.

The systems withstand pressures of up to 1000 bar, are equipped with double non-return valves and, if required, are pre-filled with special non-gumming sealing greases.

We recommend the following sealants / greases:

For emergency sealing : Equa-Lube Eighty

For emergency sealing and greasing : Ceritol.SAS 325

4. Storage instructions

Ball valves should remain in their original packaging during the entire storage period. To prevent damage, the protective caps should be left on the weld / flange ends until installation. Ball valves must always be stored in the FULLY OPEN position.



Valves should be stored in a closed, dry building.

5. Unpacking and inspection

Ball valves must be unpacked with the necessary care. After unpacking, they should be inspected for transport damage. Ball valves are supplied in the FULLY OPEN position with protective caps at both ends.



It is recommended to perform a functional check on valves after a lengthy storage period.

1. Fully close and open the ball valve.
2. Use any available access point to the valve body (drain or vent port) to check for leaks with nitrogen at 6 bar.

6. Indications on safe installation

6.1 Preparations

Ensure that no explosive atmosphere exists or develops during assembly and dismantling.

Prior to installation, check that the size, the pressure and the materials used meet the specified requirements.

Also remove any impurities that have formed during lengthy storage periods prior to installation.

6.2 Handling

For lifting purposes, slings should be placed around the ball valve only and not the gear mechanism.

Lifting points:



6.3 Installation

To avoid damaging the ball and seating rings, ball valves should be welded in place / installed in the FULLY OPEN position in which they were supplied.

In case of a fail safe closed actuator the following has to be observed:



1. If the actuator is supplied in mounted condition, the ball valve is in closed position. Before welding, the ball valve has to be put into open position! In this case you will find the indication "Attention, ball valve in closed position" on the ball valve.

2. If the actuator is supplied separately, the ball valve is supplied in open position. The actuator has to be put into open position before assembly (and after welding) and has to be mounted in this way. Only after this the ball valve may be closed again.



During welding, the temperature on the valve body in area A (see sketch) should not exceed 120°C. Weld the valve in place only in the FULLY OPEN position. Use only arc welding.

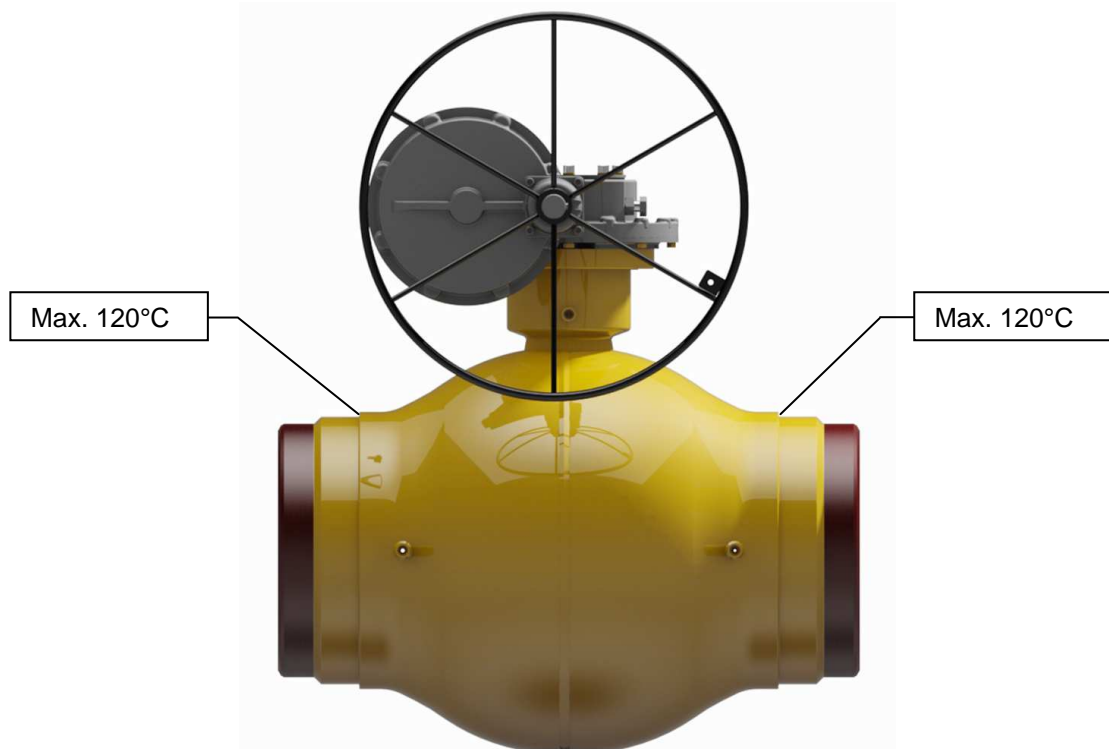

After welding and before the ball valve is operated for the first time, the line system must be rinsed thoroughly to remove impurities such as welding debris (cinder, scale, rust, etc.) that could damage the sealing elements.

The valve must be fitted using hose / tubing systems that are capable of dissipating electrostatic charges or a direct, electrostatically conductive connection to the earth potential

(leakage resistance < 106 Ω). Intentional electrical interfaces (e.g. cathodic corrosion protection) must not be short-circuited.

External piping forces and tensions must be avoided by using appropriate line designs and / or installation positions.

6.4 Water pressure test



When filling the line with water and emptying it, ensure that the ball valve is in the **FULLY OPEN** position. This prevents dirt being deposited in the valve body and sealing area.

After filling the line with water, move the ball valve to the half-open position. This balances the pressure before and after the seating rings.

Immediately after the water pressure test, proceed as follows:

1. Move the valve to the FULLY OPEN position.
2. Drain the valve using the drain connection. If a drain valve is present, open this fully. If there is only a vent plug, proceed as follows:
Turn the vent plug 3 times to loosen it, but wait until the pressure has dropped completely before removing it.
3. Re-close the drain connection.
4. Lubricate the valve using the sealant injectors for the seating rings (not the spindle) to remove any soiling.
5. Turn the valve once (closed – open).
6. Move the valve to the FULLY OPEN position.



6.5 Line drying

When drying the line, ensure that the ball valve is in the FULLY OPEN position.

6.6 Leak test

There are two ways of checking for leaks:

1. Leak test from piping to valve body.

1. Move the valve to the FULLY OPEN or FULLY CLOSED position.
2. Vent the valve using the drain connection. If a drain valve is present, open this fully. If there is only a vent plug, proceed as follows:
Turn the vent plug 3 times to loosen it, but wait until the pressure has dropped completely before removing it.
Allow sufficient time for the valve body to depressurise before checking for leaks.
3. Check whether there is a leak.
4. Use nitrogen to apply pressure to the valve body (balance the pressure with that of the line).
5. Re-close the drain connection.
6. Lubricate the valve using the sealant injectors for the seating rings (not the spindle) to remove any soiling.
7. Turn the valve once (closed – open).
8. Move the valve to the FULLY OPEN or FULLY CLOSED position.

2. Leak test from valve body to piping

1. Move the valve to the FULLY OPEN or FULLY CLOSED position.
2. Vent the valve using the drain connection. If a drain valve is present, open this fully. If there is only a vent plug, proceed as follows:
Turn the vent plug 3 times to loosen it, but wait until the pressure has dropped completely before removing it.
3. Use nitrogen to apply pressure to the valve body (do not exceed the max. operating pressure).
4. Check whether the pressure decreases (leak).
5. Adjust the pressure in the valve body to that in the line (pressure balance).
6. Re-close the drain connection.
7. Lubricate the valve using the sealant injectors for the seating rings (not the spindle) to remove any soiling.
8. Turn the valve once (closed – open).
9. Move the valve to the FULLY OPEN or FULLY CLOSED position.

7. Maintenance

If the measures described in Section 6.4 to be performed following the water pressure test have been completed, the valve is maintenance-free.

The bearings are self-lubricating and wear-resistant. The gears supplied are greased for life and therefore do not require any maintenance either.

8. Repair

8.1 Preparations

Ensure that no explosive atmosphere is present or develops during repair work.

8.2 Repairing the external coating

Any localised damage to the external polyurethane coating (Protegol 32-55) can be repaired using Protegol 32-55 L repair compound, which is supplied by the same manufacturer specifically for this purpose. It is important to follow the manufacturer's technical instructions.

Due to the fast reaction time, this repair compound is best supplied in small 0.5 kg containers. It can be supplied by RMA.

If necessary, please consult us about other coatings (e.g. for use above ground).

9. Ball valve with individual parts

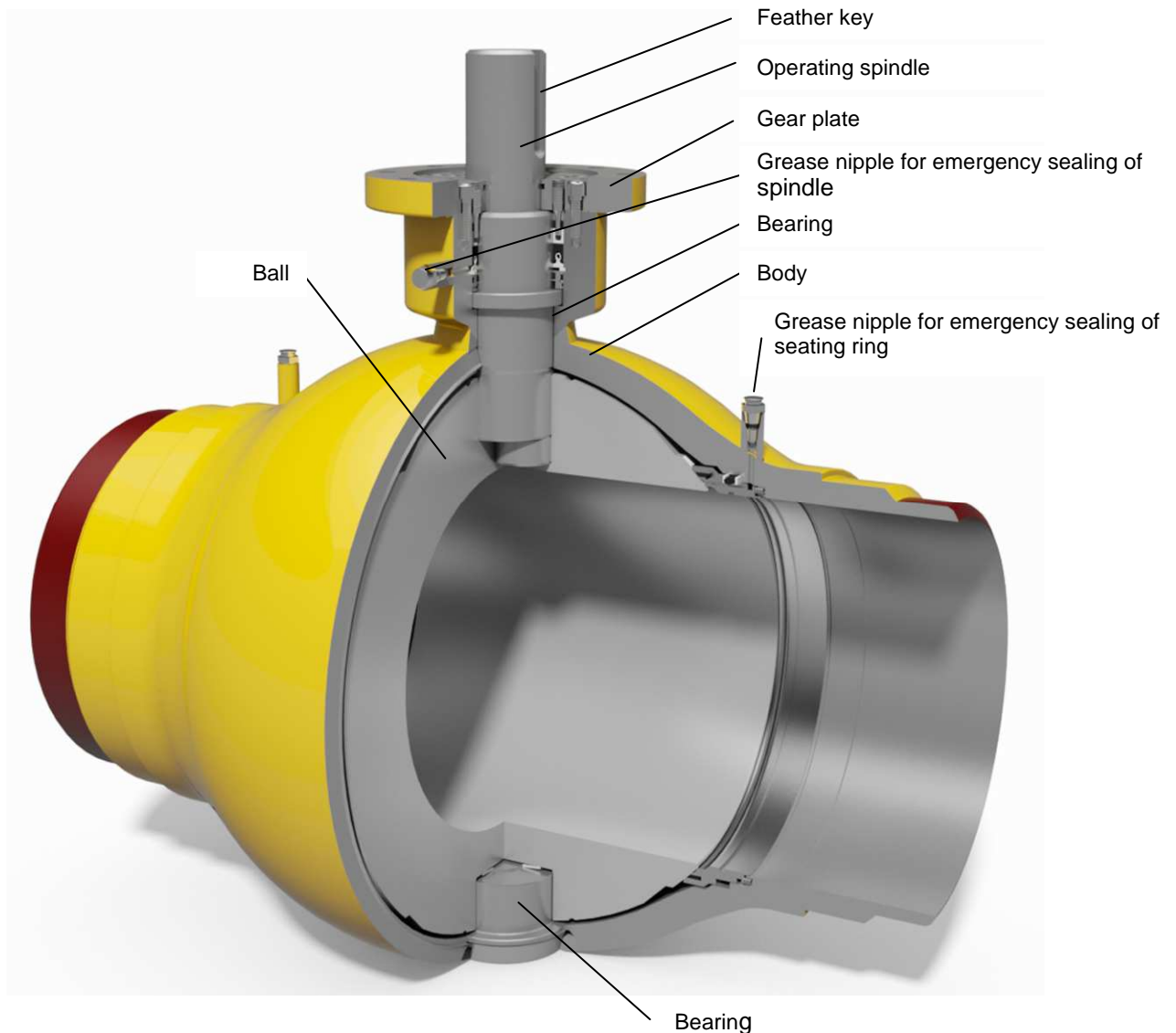

Seating rings

- Primary metallic, secondary soft-sealing:

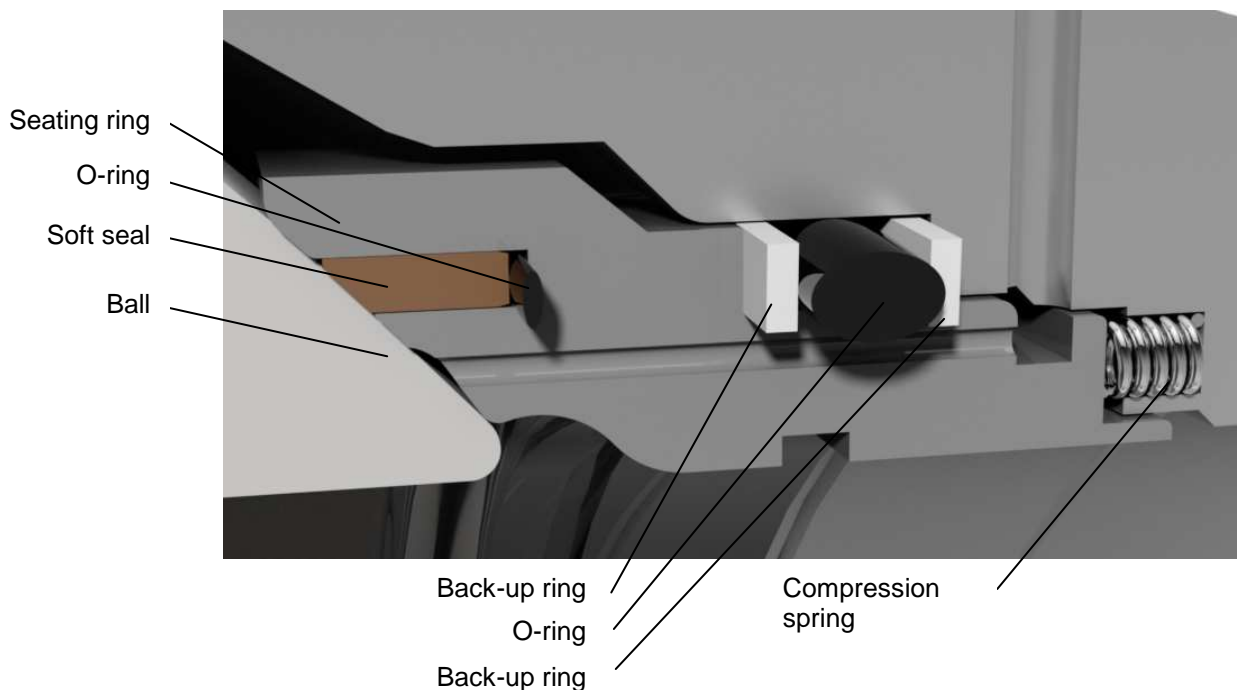

- Metallic sealing only:

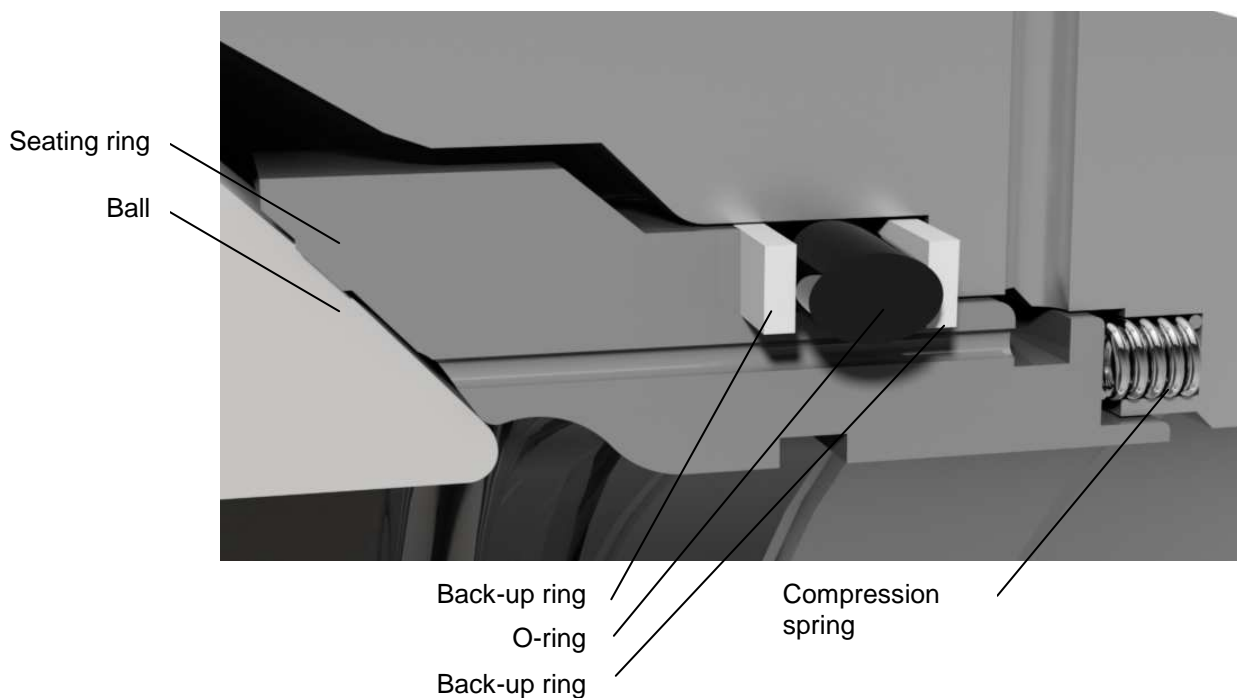

Spindle sealing

